

AUTOMATIC

QA-6500

TOP LEVEL EFFICIENCY

FEATURES

- Fully automatic feed
- Superior 50mm deep hole drilling - automatically cuts holes from 14mm ϕ - 65mm ϕ
- Boosts productivity
- Powerful two speed drill motor 400/750 RPM

SELF FEEDING & LOAD DETECTION

Feed is controlled by onboard microcomputer, it begins slowly then increases to the appropriate speed for cutter size and load conditions. Load detector indicates amount of resistance on cutter at anytime.

LIMIT SWITCH

When the drill has reached the top of its stroke, a limit switch stops the drill motor. There is also a limit switch at the bottom of drill stroke.



KEY FEATURES



MACHINE TOOLS

Load Detector

- Feed rate controlled by onboard microcomputer. Load detector shows resistance on cutter at anytime.



Light up

Two Speed Selection

- Speed can be changed to suit the type and size of cutter.

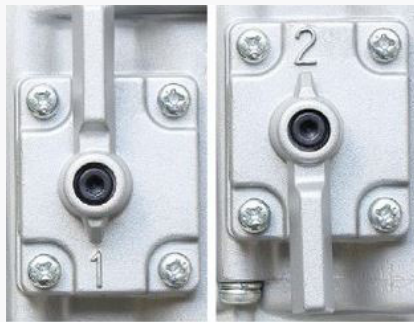

Improved Bearing Bracket

- Our precision bearing bracket aligns cutters precisely, which increases cutter life.



Optional Items

HIBROACH

- High Speed Steel One-Touch Type (25mm and 50mm depth of cut)



JETBROACH

- TCT Carbide Tipped Cutters (25mm, 35mm, 50 & 75mm depth of cut)



Always use Genuine Nitto Kohki Cutters

DIMENSIONS

QA-6500
Unit : mm

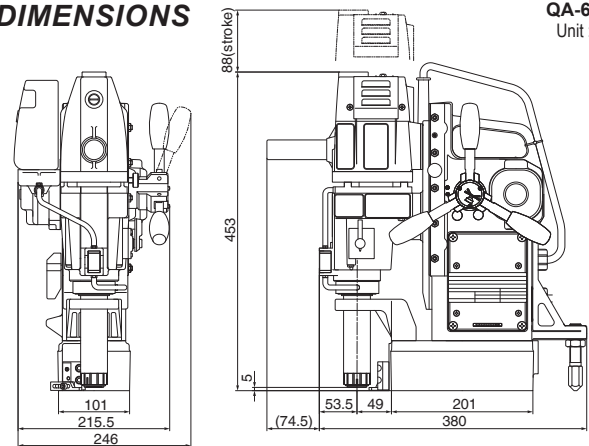

Model No.	Power Source	Rated Power Consumption	No Load Speed	Hole Diameter	Plate Thickness	Magnet Holding Power	Weight
QA-6500	220~240V AC 50/60HZ	1,010W	400/750rpm	14 - 65mm	9 - 75mm	1,000 kg/f	26kg